

ToPGATE multiplexer – flexible compact equipment for E1 streams transmission through packet networks via TDM over packet (TDMoP), Structure-Agnostic Time Division Multiplexing over Packet (SAToP), Structure-Aware Time Division Multiplexed Circuit Emulation Service over Packet Switched Network (CESoPSN) technologies. The devices provide transparent independent connection of classic telephony equipment upon a unified network infrastructure. Optic-fiber interfaces which are realized through connected SFP and CSFP modules and embedded Ethernet switch allows to construct networks with different topologies without additional equipment.

ToPGATE multiplexers are dedicated to cooperative transmission of structured and unstructured E1 carriers (G.703, G.704) and Ethernet packets through packet data network with the help of TDMoP technology. It is possible to use IP/Ethernet network and build data network for E1 transmission using ToPGATE multiplexers.

Transparent E1 carriers transmission through packet networks allows to construct new generation networks and use available equipment and services on a new level of quality and profitability.

The management for multiplexers might be implemented locally via a serial port as well as remotely through an IP network using standard or supplied with the product software. Small size allows using less space while network construction. ToPGATE equipment is a reliable, high-quality and efficient solutions for data and E1 transmission while new networks construction as well as while modernization of available ones.

E1 stream transmission technology: TDMoP, SAToP, CESoPSN

To transmit E1 streams, ToPGATE multiplexer uses technology of point-to-point virtual connection creation upon packet networks – TDM-over-Packet Network: TDMoP, PWE3 (SAToP, CESoPSN). The technology has advantages in comparison with PDH, SDH and Voice-over-IP (VoIP) technologies.

In contrast to PDH technology, it is possible to re-switch



connections among any E1 interfaces of any devices «on the fly» and to reserve ring topology in a network. Furthermore, TDMoP has higher bandwidth. E1 streams might be transmitted via available IP/Ethernet networks.

In comparison with the devices using SDH technology, ToPGATE has lower cost and opportunity to transmit E1 streams through common packet networks with low-cost infrastructure.

In contrast to VoIP technology, E1 stream data in ToPGATE is transmitted uncompressed and E1 interfaces complied to ITU-T G.703 standard specification. It allows to connect any standard telecommunication equipment without problems with compatibility. Voice data is transmitted with minimal delay and original quality. Furthermore, it is possible to connect devices with interfaces compatible with G.703 specification with frame stream structure or without it. The cost of traditional telephony equipment is lower than VoIP equipment cost, and personnel can efficiency operate with known equipment.

Apart from **TDM over Packet** (TDMoP) technology, the additional protocols are realized in new software versions of ToPGATE:

- **SAToP** (Structure-Agnostic Time Division Multiplexing over Packet) – a protocol for unstructured data transmission with time division multiplexing over packet networks (RFC 4553).
- **CESoPSN** (Structure-Aware Time Division Multiplexed Circuit Emulation Service over Packet Switched Network) - circuit emulation service for structured data with time division multiplexing over packet networks (RFC 5086)

The additional protocols of pseudo-wire transmission allow transmitting E1 carriers between ToPGATE multiplexers and other manufacturers equipment, for instance RAD Data Communications.

ToPGATE-SFP

- Compact size, no separate power supply
- Up to 2 structured or unstructured E1 streams transmission through data network without quality deterioration
- Unique algorithms of frequency recovery which provide stable operation on real networks
- Advanced monitoring and logging means
- Management via SNMP, Web, Telnet, SSH
- Opportunity to transmit separate time slots of E1 streams over Ethernet networks
- Management restrictions by IP, VLAN, operators actions logging
- Opportunity to control devices through Eltex-EMS management system



ToPGATE-SFP

Main features

ToPGATE-SFP multiplexer provides transmission of structured or unstructured E1 streams over packet networks. The device is implemented in SFP form-factor (Small Form Factor Pluggable).

The multiplexer is designed for fast and easy connection to standard SFP port of any switch. Compact size and lack of separate power supply allows fast and effective E1 streams output at any point of existing network with minimal time spending on mounting, separate power supply connection and management. Having full function set of the ToPGATE line, ToPGATE-SFP is a cost-effective alternative to separate devices for E1 stream transmission over Ethernet and IP networks on endpoints.

Features and capabilities

E1 interfaces

- Quantity: 1 or 2 in RJ-45 form-factor
- Standards: G.703, G.704, G.823
- Interface: symmetric 120 Ohm, HDB3/AMI
- Synchronisation: inner, incoming E1 stream synchronisation
- Connector: RJ-45

TDM over Packet Network (Ethernet/IP)

- TDMoP, SAToP, CESoPSN
- Transmission delay: 1-2000 ms
- 1+1 redundancy

Ethernet interface

- Standards: 1000Base-X, SGMII
- Connector: SFP

VLAN

- 802.1Q VLAN (TDMoP VLAN, MGMT VLAN)

Management interface

- IDProm, DDM
- Ethernet

Control means

- Telnet CLI, menu
- SSH
- Web interface
- SNMP v1, v2c, v3
- RADIUS, TACACS+ authentication

Dimensions

- Dimensions (WxHxD, mm): SFP (14x14x67)
- Weight 0.2 kg

Power supply

- From main device
- Maximum power consumption 1W

TopGATE-1E1-1FG

- Compact size, 19" rack mounting
- Low-cost equipment and maintenance
- Transmission of single structured or unstructured E1 stream through data network without quality deterioration
- Unique algorithms of frequency recovery which provide stable operation on real networks
- Unified interface with ToPGATE series devices for combination of 100M, 1G and 10G networks based on copper, optical and wireless technologies
- Local (via serial port Mini USB) and remote management and diagnosis
- Support for SNMP, Web, Telnet, SSH, RADIUS, TACACS+
- Opportunity to control devices through Eltex-EMS management system



TopGate-1E1-1FG

Features and capabilities

E1 interfaces

- Quantity: 1 RJ-45
- Standards: G.703, G.704, G.706, G.823
- Interface: symmetric 120 Ohm, HDB3/AMI
- Synchronisation: inner, incoming E1 stream synchronisation
- Link distance: 500 m

TDM over Packet Network (Ethernet/IP)

- TDMoP, SAToP, CESoPSN
- Transmission delay: 1-2000 ms
- 1+1 redundancy

Ethernet interfaces

- Quantity: 1 RJ-45, 1 SFP
- Type 10/100/1000 Mbps Auto MDI/MDI-X RJ-45
- Type IEEE 802.3 1000Base-X
- Support for IEEE 802.3, 802.3u, 10Base-T, 100Base-TX, 1000Base-TX standards

Management means

- Telnet CLI, menu
- SSH
- Web interface
- SNMP v1, v2c, v3
- RADIUS, TACACS+ authentication

Parameters

- MAC table: 8192 entries
- Embedded switch bandwidth: up to 2 Gbps, 2.98 Mpps;
- Maximum frame size: 10240 bytes

Capabilities

- 4 priority queues 802.1p
- QoS based on: switch port, VLAN, DSCP, source/destination MAC address
- VLAN: IEEE 802.1Q standard, values range from 0 to 4095, Q-in-Q - double tagging
- IGMP Snooping
- MVR (Multicast VLAN Registration)
- Local traffic mirroring
- Support for NAT for E1 transmission
- PIRL – Port Ingress Rate Limit – bandwidth limiting for incoming traffic per ports
- FlowControl
- SAFilter – MAC address filtering
- Scheduling – frames output planning
- DyingGasp – message sending to syslog server in case of powerdown or reload

Dimensions

- Dimensions (WxHxD, mm): 82x26x85.5, 19" form-factor
- Weight 0.25 kg

Power supply

- 220 VAC, 12 VDC (the converter ~220V into 12V is in the package)
- Maximum power consumption 6W

TopGATE-2E1-1F

- Compact size, 19" rack mounting
- Low-cost equipment and maintenance
- Transmission of 2 structured or unstructured E1 streams through data network without quality deterioration
- Unique algorithms of frequency recovery which provide stable operation on real networks
- Unified interface with ToPGATE series devices for combination of 100M, 1G and 10G networks based on copper, optical and wireless technologies
- Local (via serial port Mini USB) and remote management and diagnosis
- Support for SNMP, Web, Telnet, SSH, RADIUS, TACACS+
- Opportunity to control devices through Eltex-EMS management system



TopGATE-2E1-1F

Features and capabilities

E1 interfaces

- Quantity: 2 RJ-45
- Standards: G.703, G.704, G.706, G.823
- Interface: symmetric 120 Ohm, HDB3/AMI
- Synchronisation: inner, incoming E1 stream synchronisation
- Link distance: 500 m

TDM over Packet Network (Ethernet/IP)

- TDMoP, SAToP, CESoPSN
- Transmission delay: 1-2000 ms
- 1+1 redundancy

Ethernet interfaces

- Quantity: 1 RJ-45
- Type 10/100/1000 Mbps Auto MDI/MDI-X RJ-45
- Support for IEEE 802.3, 802.3u, 10Base-T, 100Base-T, 1000Base-TX standards
- Link distance 160m

VLAN

- 802.1Q VLAN (TDMoP VLAN, MGMT VLAN)

Parameters and capabilities

- Maximum frame size: 1522
- Use of DSCP in QoS
- Support for NAT while E1 streams transmission

Management means

- Telnet CLI, menu
- SSH
- Web interface
- SNMP v1, v2c, v3
- RADIUS, TACACS+ authentication

Dimensions

- Dimensions (WxHxD, mm): 82x26x85.5, 19" form-factor
- Weight 0.25 kg

Power supply

- 220 VAC, 12 VDC (the convector ~220V into 12V is in the package)
- Maximum power consumption 5W

TopGATE-4E1-2FG

- Support for CSFP (Compact Small Form-factor Pluggable) modules. 2 optic-fiber lines can be connected through a single CSFP module
- Opportunity to view IDProm and DDM (Digital Diagnostics Monitoring) of SFP/CSFP modules
- DyingGasp
- Transmission of 4 structured or unstructured E1 streams through data network without quality deterioration
- Unique algorithms of frequency recovery which provide stable operation on real networks
- Unified interface with ToPGATE series devices for combination of 100M, 1G and 10G networks based on cooper, optical and wireless technologies
- Local traffic mirroring
- MVR (Multicast VLAN Registration) – multicast VLANs registration, which allows to transmit multicast stream in a single VLAN, while end users are capable to obtain it being in different VLANs.

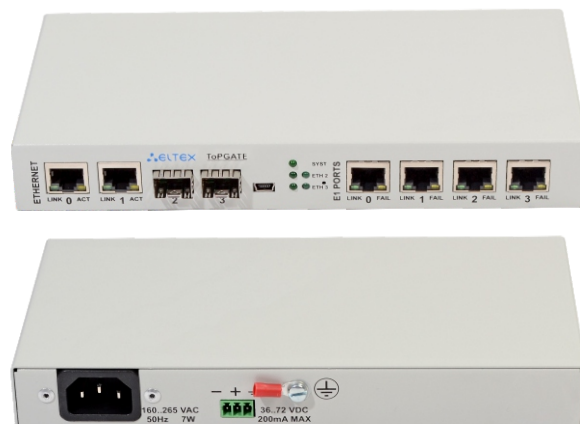

TopGATE-4E1-2FG

- Support for RSTP protocols for networks with complicated topology with redundancy, e.g. ring with spurs, tree
- Support for SNMP, Web, Telnet, SSH, RADIUS, TACACS+
- Local and remote management and diagnosis
- Opportunity to control devices through Eltex-EMS management system

Features and capabilities

E1 interfaces

- Quantity: 4 RJ-45
- Standards: G.703, G.704, G.706, G.823
- Interface: symmetric 120 Ohm, HDB3/AMI
- Synchronisation: inner, incoming E1 stream synchronisation
- Link distance: 500 m

TDM over Packet Network (Ethernet/IP)

- TDMoP, SAToP, CESoPSN
- Transmission delay: 1–2000 ms
- 1+1 redundancy

Ethernet interfaces

- Quantity: 4
- 2 Gigabit Ethernet interfaces, 2 SFP/CSFP Gigabit interfaces
- Cooper interfaces standards: IEEE 802.3i 10Base-T, IEEE 802.3u 100Base-TX, IEEE 802.3ab 1000Base-T, IEEE 802.3x Flow Control
- Optical interfaces standards: IEEE 802.3u 100Base-FX, IEEE 802.3z 1000Base-X, IEEE 802.3x Flow Control

Management

- Local management: Mini USB connector
- Management trough IP network: Telnet CLI, menu, SSH, Web interface, SNMP v1, v2c, v3
- RADIUS, TACACS+ authentication

Capabilities

- MAC table: 1024 entries
- Embedded switch bandwidth: up 6 Gbps, 9 Mpps;
- Maximum frame size: 1632 bytes
- 4 priority queues 802.1p;
- QoS based on: switch port, VLAN, DSCP, source/destination MAC address
- VLAN: IEEE 802.1Q standard, Q-in-Q - double tagging;
- IGMP Snooping;
- Redundancy: STP (IEEE 802.1.d), RSTP (IEEE 802.1.w), Root guard
- Local traffic mirroring
- Support for NAT for E1 streams transmission
- MVR (Multicast VLAN Registration)
- FlowControl
- SAFilter – MAC address filtering
- Scheduling – frames output planning
- DyingGasp – message sending to syslog server in case of powerdown or reload

Dimensions

- Dimensions (WxHxD, mm): 215x28.5x105, 19" form-factor
- Weight 0.8 kg

Power supply

- 220 VAC, -48 VDC
- Maximum power consumption 6W

TopGATE-8E1-2FG

- Support for CSFP (Compact Small Form-factor Pluggable) modules. 2 optic-fiber lines can be connected through a single CSFP module
- Opportunity to view IDProm and DDM (Digital Diagnostics Monitoring) of SFP/CSFP modules
- DyingGasp
- Transmission of 8 structured or unstructured E1 streams through data network without quality deterioration
- Unique algorithms of frequency recovery which provide stable operation on real networks
- Unified interface with ToPGATE series devices for combination of 100M, 1G and 10G networks based on cooper, optical and wireless technologies
- Local traffic mirroring
- MVR (Multicast VLAN Registration) – multicast VLANs registration, which allows to transmit multicast stream in a single VLAN, while end users are capable to obtain it being in different VLANs.



TopGATE-8E1-2FG

- Support for RSTP protocols for networks with complicated topology with redundancy, e.g. ring with spurs, tree
- Support for SNMP, Web, Telnet
- Local and remote management and diagnosis
- Opportunity to control devices through Eltex-EMS management system

Features and capabilities

E1 interfaces

- Quantity: 8 RJ-45
- Standards: G.703, G.704, G.706, G.823
- Interface: symmetric 120 Ohm, HDB3/AMI
- Synchronisation: inner, incoming E1 stream synchronisation
- Link distance: 500 m

TDM over Packet Network (Ethernet/IP)

- TDMoP, SAToP, CESoPSN
- Transmission delay: 1–2000 ms
- 1+1 redundancy

Ethernet interfaces

- Quantity: 4
- 2 Gigabit Ethernet interfaces, 1 SFP/CSFP Gigabit interface, 1 SFP Gigabit interface
- Cooper interfaces standards: IEEE 802.3i 10Base-T, IEEE 802.3u 100Base-TX, IEEE 802.3ab 1000Base-T, IEEE 802.3x Flow Control
- Optical interfaces standards: IEEE 802.3u 100Base-FX, IEEE 802.3z 1000Base-X, IEEE 802.3x Flow Control

Management

- Local management: 1USB type B port, 1 RJ-45 port
- Management through IP network: Telnet CLI, menu, SSH, Web interface, SNMP v1, v2c, v3
- Equipment management, e.g. PBX management via AUX port
- RADIUS, TACACS+ authentication

Capabilities

- MAC table: 1024 entries
- Switching: on line speed
- Maximum frame size: 1632 bytes
- IGMP Snooping
- Port mirroring
- Support for NAT for E1 streams transmission
- VLAN: IEEE 802.1Q standard, values range from 0 to 4095, Q-in-Q - double tagging;
- MVR (Multicast VLAN Registration)
- 4 priority queues 802.1p
- QoS based on: switch port, VLAN, DSCP, source/destination MAC address
- FlowControl
- SAFilter – MAC address filtering
- Scheduling – frames output planning
- Dying Gasp – message sending to syslog server in case of powerdown or reload

Dimensions

- Dimensions (WxHxD, mm): 215x44x150, 19" form-factor
- Weight 1,2 kg

Power supply

- 220 VAC, -48 VDC
- Maximum power consumption 15W

TopGATE-16E1-2FG

- Support for CSFP (Compact Small Form-factor Pluggable) modules. 2 optic-fiber lines can be connected through a single CSFP module
- Opportunity to view IDProm and DDM (Digital Diagnostics Monitoring) of SFP/CSFP modules
- DyingGasp
- Transmission of 16 structured or unstructured E1 streams through data network without quality deterioration
- Unique algorithms of frequency recovery which provide stable operation on real networks
- Unified interface with ToPGATE series devices for combination of 100M, 1G and 10G networks based on cooper, optical and wireless technologies
- Local traffic mirroring
- MVR (Multicast VLAN Registration) – multicast VLANs registration, which allows to transmit multicast stream in a single VLAN, while end users are capable to obtain it being in different VLANs.



TopGATE-16E1-2FG

- Support for RSTP protocols for networks with complicated topology with redundancy, e.g. ring with spurs, tree
- Support for SNMP, Web, Telnet, SSH, RADIUS, TACACS+
- Local and remote management and diagnosis
- Opportunity to control devices through Eltex-EMS management system

Features and capabilities

E1 interfaces

- Quantity: 16 RJ-45
- Standards: G.703, G.704, G.706, G.823
- Interface: symmetric 120 Ohm, HDB3/AMI
- Synchronisation: inner, incoming E1 stream synchronisation
- Link distance: 500 m

Ethernet interfaces

- Quantity: 4
- 2 Gigabit Ethernet interfaces, 1 SFP/CSFP Gigabit interface, 1 SFP Gigabit interface
- Cooper interfaces standards: IEEE 802.3i 10Base-T, IEEE 802.3u 100Base-TX, IEEE 802.3ab 1000Base-T, IEEE 802.3x Flow Control
- Optical interfaces standards: IEEE 802.3u 100Base-FX, IEEE 802.3z 1000Base-X, IEEE 802.3x Flow Control

TDM over Packet Network (Ethernet/IP)

- TDMoP, SAToP, CESoPSN
- Transmission delay: 1–2000 ms
- 1+1 redundancy

Parameters and capabilities

- MAC table: 1024 entries
- Switching: on line speed
- Maximum frame size: 1632 bytes
- IGMP Snooping
- Port mirroring
- Support for NAT for E1 streams transmission

- VLAN: IEEE 802.1Q standard, values range from 0 to 4095, Q-in-Q – double tagging;
- MVR (Multicast VLAN Registration)
- 4 priority queues 802.1p
- QoS based on: switch port, VLAN, DSCP, source/destination MAC address
- FlowControl
- SAFilter – MAC address filtering
- Scheduling – frames output planning
- Dying Gasp – message sending to syslog server in case of powerdown or reload

Management

- Local management: 1 USB type B port, 1 RS-232
- Management through IP network: Telnet CLI, menu, SSH, Web interface, SNMP v1, v2c, v3
- Equipment management, e.g. PBX management via AUX port
- RADIUS, TACACS+ authentication

Dimensions

- Dimensions (WxHxD, mm): 430x44x150, 19" form-factor;
- Weight 2 kg;

Power supply

- 220 VAC, -48 VDC
- Maximum power consumption 15 W

ToPGATE-24E1-2FG

- Support for CSFP (Compact Small Form-factor Pluggable) modules. 2 optic-fiber lines can be connected through a single CSFP module
- Opportunity to view IDProm and DDM (Digital Diagnostics Monitoring) of SFP/CSFP modules
- DyingGasp
- Transmission of 24 structured or unstructured E1 streams through data network without quality deterioration
- Unique algorithms of frequency recovery which provide stable operation on real networks
- Unified interface with ToPGATE series devices for combination 100M, 1G and 10G networks based on cooper, optical and wireless technologies
- Local traffic mirroring
- MVR (Multicast VLAN Registration) – multicast VLANs registration, which allows to transmit multicast stream in a single VLAN, while end users are capable to obtain it being in different VLANs.

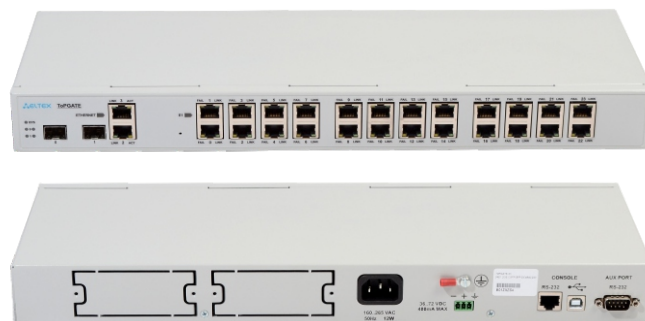

ToPGATE-24E1-2FG

- Support for RSTP protocols for networks with complicated topology with redundancy, e.g. ring with spurs, tree
- Support for SNMP, Web, Telnet, SSH, RADIUS, TACACS+
- Local and remote management and diagnosis
- Opportunity to control devices through Eltex-EMS management system

Features and capabilities

E1 interfaces

- Quantity: 24 RJ-45
- Standards: G.703, G.704, G.706, G.823
- Interface: symmetric 120 Ohm, HDB3/AMI
- Synchronisation: inner, incoming E1 stream synchronisation
- Link distance: 500 m

Ethernet interfaces

- Quantity: 4
- 2 Gigabit Ethernet interfaces, 1 SFP/CSFP Gigabit interface, 1 SFP Gigabit interface
- Cooper interfaces standards: IEEE 802.3i 10Base-T, IEEE 802.3u 100Base-TX, IEEE 802.3ab 1000Base-T, IEEE 802.3x Flow Control
- Optical interfaces standards: IEEE 802.3u 100Base-FX, IEEE 802.3z 1000Base-X, IEEE 802.3x Flow Control

TDM over Packet Network (Ethernet/IP)

- TDMoP, SAToP, CESoPSN
- Transmission delay: 1–2000 ms
- 1+1 redundancy

Parameters and capabilities

- MAC table: 1024 entries
- Switching: on line speed
- Maximum frame size: 1632 bytes
- IGMP Snooping
- Port mirroring
- Support for NAT for E1 streams transmission

- VLAN: IEEE 802.1Q standard, values range from 0 to 4095, Q-in-Q – double tagging;
- MVR (Multicast VLAN Registration)
- 4 priority queues 802.1p
- QoS based on: switch port, VLAN, DSCP, source/destination MAC address
- FlowControl
- SAFilter – MAC address filtering
- Scheduling – frames output planning
- Dying Gasp – message sending to syslog server in case of powerdown or reload

Management

- Local management: 1 USB type B port, 1 RS-232
- Management through IP network: Telnet CLI, menu, SSH, Web interface, SNMP v1, v2c, v3
- Equipment management, e.g. PBX management via AUX port
- RADIUS, TACACS+ authentication

Dimensions

- Dimensions (WxHxD, mm): 430x44x150, 19" form-factor;
- Weight 2 kg;

Power supply

- 220 VAC, -48 VDC
- Maximum power consumption 15 W

TopGATE-2STM1-2FG

TopGATE-2STM1-2FG multiplexer is dedicated for demultiplexing of structured and unstructured E1 streams (G.703, G.704) out of STM-1 stream (SDH) and for transmission of this data through packet data network (Ethernet) via TDMoP.

Due to the embedded full-featured Gigabit Ethernet L2+ switch and 2 optic-fiber interfaces (up to 80 km link distance for a single fiber), there is an opportunity to build small transport networks without additional equipment.

- Up to 126 E1 streams transmission via TDMoP that provides transparent connection of any E1 equipment without quality deterioration
- Embedded full-featured L2 switch supports all the required standards for modern networks construction: traffic prioritization with 4 priority queues, VLAN
- Building of combined networks with different bandwidth and technologies using 100M, 1G and 10G part of networks. Opportunity of bandwidth extension on Ethernet level or increasing of E1 streams quantity



TopGATE-2STM1-2FG

- 2 interfaces of 1000Base-X for optic lines connection and support for RSTP (802.1w) for effective and fault-tolerant operation in modern distributed Ethernet networks with complicated ring topology with redundancy, e.g. ring with spurs, tree
- Local (through the serial USB port) and remote management and diagnosis
- Support for SNMP, Web, Telnet, local management console, port mirroring, opportunity to save and modify text configurations

Features and capabilities

STM1 interfaces

- Quantity: 2 SFP
- Standard: G.707
- Synchronisation: inner, incoming E1 stream synchronisation
- Transmission delay: from 2.5 ms to 512 ms

Ethernet interfaces

- Quantity: 4
- 2 Gigabit Ethernet (RJ-45)
- 2 Gigabit Ethernet (SFP)
- Cooper interfaces standards: IEEE 802.3i 10Base-T, IEEE 802.3u 100Base-TX, IEEE 802.3ab 1000Base-T, IEEE 802.3x Flow Control
- Optical interfaces standards: IEEE 802.3u 100Base-FX, IEEE 802.3z 1000Base-X, IEEE 802.3x Flow Control

Parameters and capabilities

- Bandwidth: 3.9 Gbps, 5.95 Mpps
- MAC table: 1024 entries
- Maximum frame size: 1632 bytes
- IGMP Snooping
- Redundancy: STP (802.1.d), RSTP (802.1w), Root guard
- Port mirroring
- DHCP
- Static Mac

- 4 priority queues 802.1p
- CoS based on: switch port, VLAN, DSCP, TOS, source/destination MAC address
- Bandwidth management: step 64 kB
- VLAN: IEEE 802.1Q standard, values range from 0 to 4095, Q-in-Q – double tagging;
- MVR (Multicast VLAN Registration)

Management

- Local management: 1 USB port, 1 RS-232
- Management through IP network: Telnet CLI, menu, Web interface, SNMP v1, v2
- Soft update NMS
- Equipment management, e.g. PBX management via AUX port

Dimensions

- Dimensions (WxHxD, mm): 430x44x150, 19" form-factor, 1U, wall mounting
- Weight 2 kg







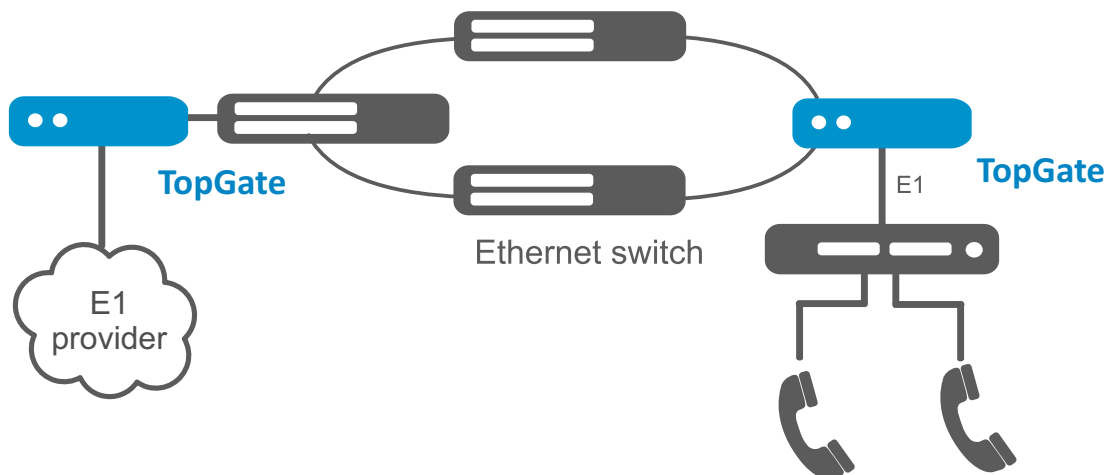

Power supply

- 220 VAC, -48 VDC
- Maximum power consumption 10 W

Application scheme



Ordering information

Name	Description	Image
ToPGATE-SFP	metal case SFP form-factor, 1 E1 interface, powered by a switch	
ToPGATE-1E1-1FG	metal case 82x26x85, 1 E1 interface, 1 Gigabit Ethernet interface, 1 Gigabit Ethernet SFP* interface, ~220V power adapter	
ToPGATE-2E1-1F	metal case 82x26x85, 2 E1 interfaces, 1 Fast Ethernet interface, ~220V power adapter	
ToPGATE-4E1-2FG	metal case 10", 4 E1 interfaces, 2 Gigabit Ethernet interfaces, 2 SFP/CSFP* interfaces 1Gb, ~220VAC, -48VDC	
ToPGATE-8E1-2FG	metal case 10", 8 E1 interfaces, 2 Gigabit Ethernet interfaces, SFP/CSFP* interface 1Gb, SFP interface 1Gb, ~220VAC, -48VDC	
ToPGATE-16E1-2FG	metal case 19", 16 E1 interfaces, 2 Gigabit Ethernet interfaces, SFP/CSFP* interface 1Gb, SFP interface 1Gb, ~220VAC, -48VDC	
ToPGATE-24E1-2FG	metal case 19", 24 E1 interfaces, 2 Gigabit Ethernet interfaces, SFP/CSFP* interface 1Gb, SFP interface 1Gb, ~220VAC, -48VDC	
ToPGATE-2STM1-2FG	metal case 19", 2 STM-1 interfaces, 2 Gigabit Ethernet interfaces (RJ-45), 2 Gigabit Ethernet interfaces (SFP*), 2 changeable power supplies, 220VAC, -48VDC	

* SFP/CSFP modules are not included into supply package

Contact Us

About EltexAlatau

+7 (727) 220 76 10

post@eltexalatau.kz

www.eltexalatau.kz

EltexAlatau company is one of the first communication equipment manufacturers in Kazakhstan established in 2012. The main focus of the enterprise is a set of solutions and the opportunity of their seamless connection to the customer's infrastructure.